

University of Texas at Arlington

**MavMatrix**

---

Biology Theses

Department of Biology

---

2023

# IMPACTS OF DAM REMOVAL ON CYANOBACTERIA BLOOMS AND ZOOPLANKTON COMMUNITY IN HYPEREUTROPHIC UPPER KLAMATH LAKE

Pruett Noelle Kasey

Follow this and additional works at: [https://mavmatrix.uta.edu/biology\\_theses](https://mavmatrix.uta.edu/biology_theses)



Part of the [Biology Commons](#)

---

## Recommended Citation

Kasey, Pruet Noelle, "IMPACTS OF DAM REMOVAL ON CYANOBACTERIA BLOOMS AND ZOOPLANKTON COMMUNITY IN HYPEREUTROPHIC UPPER KLAMATH LAKE" (2023). *Biology Theses*. 70.

[https://mavmatrix.uta.edu/biology\\_theses/70](https://mavmatrix.uta.edu/biology_theses/70)

This Thesis is brought to you for free and open access by the Department of Biology at MavMatrix. It has been accepted for inclusion in Biology Theses by an authorized administrator of MavMatrix. For more information, please contact [leah.mccurdy@uta.edu](mailto:leah.mccurdy@uta.edu), [erica.rousseau@uta.edu](mailto:erica.rousseau@uta.edu), [vanessa.garrett@uta.edu](mailto:vanessa.garrett@uta.edu).

IMPACTS OF DAM REMOVAL ON CYANOBACTERIA BLOOMS AND ZOOPLANKTON COMMUNITY IN  
HYPEREUTROPHIC UPPER KLAMATH LAKE

by

Kasey Noelle Pruett

THESIS

Submitted in Partial Fulfillment of the Requirements

for the Degree of Master of Science in Biology at

The University of Texas at Arlington

August 2023

Arlington, Texas

Supervising Committee:

Melissa Walsh, Supervising Professor

Matthew Walsh

Walter Schargel

Copyright © by Kasey Noelle Pruett 2023

All Rights Reserved

# ABSTRACT

## IMPACTS OF DAM REMOVAL ON CYANOBACTERIA BLOOMS AND ZOOPLANKTON COMMUNITY IN HYPEREUTROPHIC UPPER KLAMATH LAKE

Kasey Noelle Pruett, MS

The University of Texas at Arlington, 2023

Supervising Professor: Melissa Walsh

The Chiloquin Dam was removed from the Sprague River in 2008 to restore the natural hydrology of Upper Klamath Lake (UKL), allow fish access to historical spawning grounds, and alleviate the effects of long-term eutrophication. This provided a natural opportunity to investigate the effects of restoration efforts on eutrophication. Using a 10-year dataset including 5 years before and 5 years after dam removal, we developed a consensus modeling approach to investigate factors contributing to the cyanobacteria blooms, observe changes in the ecosystem since the recovery efforts, and to assess the performances of three model types: logistic regression, random forest, and classification tree. Our results showed that cyanobacteria cell counts decreased significantly after dam removal and that pH, temperature and total phosphorus were important for predicting bloom presence both before and after dam removal. Classification trees revealed that reductions in both average total phosphorus concentrations and average water temperatures exhibited synergistic control over bloom presence. The dam removal also resulted in shifts in zooplankton populations. Copepods increased post-dam removal, but chydorids decreased. Previous studies showed that the chydorid species endemic to UKL

preferentially consume filamentous cyanobacteria, whereas copepods prefer algae. The changes in these two populations could indicate an ecological shift in the lake post-dam and our results suggest that eutrophication has been reduced.

# CONTENTS

ABSTRACT.....	ii
LIST OF FIGURES.....	v
LIST OF TABLES.....	vi
ACKNOWLEDGEMTS.....	vii
CHAPTER 1.....	1
INTRODUCTION.....	1
MATERIALS & METHODS.....	5
RESULTS.....	9
DISCUSSION.....	12
CONCLUSIONS.....	17
REFERENCES.....	19

## LIST OF FIGURES

### CHAPTER 1

Figure 1 Pre-/Post- Boxplots.....	26
Figure 2 Pre-Removal Classification Tree .....	29
Figure 3 Post-Removal Classification Tree.....	31

# LIST OF TABLES

## CHAPTER 1

Table 1 Variable Descriptions .....	24
Table 2 Algorithm Strengths & Weaknesses .....	25
Table 3 Model Prediction Results.....	27
Table 4 Variable Importance Rankings.....	28
Table 5 Variable Importance Rankings.....	30



## ACKNOWLEDGEMENTS

I am truly grateful to Dr. Melissa Walsh for granting me the opportunity to work in her lab and for making this research project possible. I appreciate the wisdom and encouragement I received from Dr. Melissa Walsh as well as the rest of my committee – Dr. Matt Walsh and Dr. Walter Schargel. Thank you to my family and friends for supporting my interests and encouraging me to continue pursuing my dreams. Last, but not least, thank you to my grandma Falba for believing in me enough for the both of us.

# CHAPTER 1

## INTRODUCTION

Research has shown that the construction of dams in rivers can alter local stream communities (Czerniawski & Domagała 2014), elevate water temperatures within and downstream of reservoirs (Zaidel et al., 2021), and increase nutrient concentrations which subsequently facilitates cyanobacteria growth (Baldwin et al 2009; Friedl G & Wuest A 2002; Nilsson & Renöfält 2008). For this reason, there has been motivation in recent years to remove dams to save endemic species (Ellsworth et al., 2009; Ellsworth & VanderKooi, 2011), restore natural hydrology (Nilsson & Renöfält 2008), and improve water quality (Genzoli et al., 2021). As of 2017 1,200 dams have been deconstructed in the United States. Less than 10% of these projects have studies associated with them, and of the research conducted, few investigated biological or ecological impacts on the related waterway (Bednarek, 2001; Bellmore et al., 2017). However, one recent study used a forecasting model to show that dam discharges may serve to control downstream cyanobacterial blooms dependent on the flow rate and temperature of the water released (Kim et al 2021).

The relationship between manmade reservoirs and cyanobacteria blooms, or harmful algal blooms (HABs), is well documented. Dams impede the flow of water and dissolved nutrients alike causing nitrogen and phosphorus to collect within impoundments (Maavara et al 2020). Studies have also shown that dams lead to elevated water temperatures in reservoirs and in downstream reaches (Zaidel et al., 2021). Researchers have attributed cyanobacteria bloom development to both elevated temperatures and eutrophication (Smucker et al., 2021). However, the rate of increase in blooms is greater than can be explained by global warming and eutrophication alone (Ho et al., 2019). Research regarding the relationship between dams and cyanobacteria implicates residence times as a contributing factor. Osami et al (1998) periodically observed low chlorophyll-a levels despite high nutrient

concentrations in the Asahi River Dam reservoir. Their investigation revealed that long hydraulic retention times, in addition to nutrient availability and water temperature, were necessary to allow the bloom time to develop (Osami et al., 1998). A more recent study found that pigment-based cyanobacteria had a significant positive ( $p < 0.01$ ) relationship with both temperature and hydraulic retention times behind a continuous weir system located in Nakdong River, Korea. Reduced residence time and turbidity-related light reduction worked in concert to inhibit cyanobacterial growth despite rain induced influxes of available  $\text{PO}_4^{3-}$ . They proposed that regular discharges may interrupt the growth patterns of the blooms and prevent their development (Choi et al., 2020). However, Baldwin et al (2009) demonstrated that if an impoundment is conducive to bloom growth, then discharges may not prevent blooms but increase eutrophication and subsequent bloom production downstream of a dam. There is little consensus on how to prevent or reduce cyanobacteria blooms in a dammed waterway, but it is clear that low flow characteristics inherent to dams make them vulnerable to nutrient loading, solar warming and ultimately cyanobacteria bloom growth (Huisman et al., 2018; Maavara et al., 2020; Zaidel et al., 2021).

Large cyanobacteria blooms are environmentally problematic as they interrupt natural processes and degrade the functionality of ecosystems (Ekvall et al., 2014; Huisman et al., 2018; Smucker et al., 2021). Cyanobacteria limit energy transfer from primary producers to higher trophic levels by producing colonies or filaments too large for zooplankton consumption (Huisman et al., 2018; Tönno et al., 2016). Also, many species of cyanobacteria emit lethal cyanotoxins (Berens McCabe et al., 2021; Carmichael et al., 2000; Holland & Kinnear, 2013), and bloom senescence can cause hypoxia leading to fish kills (Sevrin-Reyssac & Pletikosic, 1990). Additionally, long-term studies have shown an upward trend in the size of cyanobacteria blooms in recent years which has escalated cyanotoxin-related human health risks. (Ho et al., 2019; Smucker et al., 2021). Finding effective management strategies to reduce the harmful effects of cyanobacteria blooms has become increasingly urgent as they have continued expand.

Studies of hydrological changes associated with dam removals indicate that restoring natural hydrology can affect the underlying physico-chemical infrastructure of the ecosystem within the former impoundment and downstream of the former dam site (Abbott et al., 2022; Bednarek, 2001; Bellmore et al., 2019; Zaidel et al 2021). Altering this infrastructure can ultimately lead to larger ecological impacts, such as changes in the local stream community (Bellmore et al., 2019). A study conducted during the removal of two dams (Elwha Dam and Glines Canyon Dam) on the Elwha River in western Washington revealed changes in water quality parameters such as nutrient content, turbidity, and water temperature downstream of the dam site. These changes were correlated with decreases in downstream macroinvertebrate populations (Foley et al., 2017). However, the outcome will vary based on the unique characteristics of the waterway, the dam itself, and the surrounding land (Bellmore et al., 2019; Nilsson & Renöfält, 2008). For instance, Manatawny Creek responded differently to dam deconstruction than did the Elwha River. The creek exhibited shifts in the stream community from lentic to lotic taxa, but little changed in downstream water quality parameters. The disparity between the two cases is likely related to the fact that the Manatawny Dam was 2m tall resulting in spillover and low water residence times, whereas the Elwha Dam was 32m tall and the Glines Canyon Dam was 64m tall so that connectivity on the Elwha River was more limited prior to the dam removals (Bushaw-Newton et al., 2002; Foley et al., 2017). Bellmore et al (2019) used conceptual predictive models to show that recovery after dam removal is possible, but the rate and trajectory of environmental changes are dependent on the specific characteristics of each location. This reinforces statements from his previous paper discussing the need for additional research focusing on the environmental impacts of dam removals (Bellmore et al., 2017).

This research project used data from the Upper Klamath Lake to investigate the impacts of dam deconstruction on cyanobacteria bloom presence, water quality parameters, and zooplankton communities. Each water quality parameter used in this study was selected based on prior research that

demonstrated its relationship to cyanobacteria. Additionally, we used biomass for three zooplankton groups. We selected copepod nauplii, chydorids, and Daphnia. These groups are an important part of UKL's food web (Markle & Clauson, 2006), and each has a unique relationship with cyanobacteria blooms. Studies indicate that cyanobacteria bloom presence leads to a shift in the zooplankton communities involving a decline in Daphnia and an increase in copepods and smaller cladocerans (Ger et al., 2014; Tönno et al., 2016). Predictive modeling indicates that zooplankton populations in general may be severely decreased in the wake of a dam removal. They are likely to recover once turbidity subsides, but that may take years (Bellmore et al., 2019). Also, species specific thresholds and mid-food web positioning make zooplankton meaningful environmental indicators (Jeppesen et al., 2011). For instance, researchers have observed changes in population dynamics dependent on food, pH, and temperature conditions (de Eyto & Irvine, 2001).

The Chiloquin Dam, located on the Sprague River upstream of UKL, was constructed in 1914, and removed in 2008 (Ellsworth & VanderKooi, 2011). UKL is a shallow lake (2.5m deep) located in southern Oregon with a history of eutrophication (Bradbury et al., 2004), harmful algal blooms (Bortleson & Fretwell, 1993), and declining fish populations, including the endangered Shortnose Sucker fish and Lost River Sucker fish (Bortleson & Fretwell, 1993; Burdick, Hereford, et al., 2020; Burdick, Hewitt, et al., 2020). The species of cyanobacteria found in UKL, *A. flos-aquae*, contains specialized cells called heterocysts which facilitate atmospheric nitrogen-fixing to compensate for limiting nitrogen levels (Huisman et al., 2018; Yamamoto & Nakahara, 2005). The *A. flos-aquae* blooms in UKL do not produce toxins, but they can have negative impacts on fish and other biota by causing large fluctuations in dissolved oxygen levels, limiting availability of nutritious food sources, and contributing to the lake's high pH (Bortleson & Fretwell, 1993; Burdick, Hereford, et al., 2020; Burdick, Hewitt, et al., 2020; Caldwell Eldridge et al., 2013). Additionally, as the bloom senesces in late summer or early fall it releases

large amounts of nitrogen and phosphorus which incites the formation of a toxic *Microcystis aeruginosa* bloom (Burdick, Hewitt, et al., 2020).

The dam was removed to allow sucker fish access to historical spawning grounds and recover the population (Ellsworth et al., 2009; Helper, n.d.). According to recent studies the fish have not recovered, which is thought to be related to the lake's poor water quality (Burdick, Hereford, et al., 2020; Burdick, Hewitt, et al., 2020; Burdick & Martin, 2017). Currently UKL is classified as hypereutrophic and has yearly cyanobacteria blooms composed almost exclusively of *Aphanizomenon flos-aquae* (Martin et al., 2019; Snyder D.T. & Morace JL, 1997).

The purpose of this analysis is to investigate the relationships between water quality, cyanobacteria, and zooplankton in Upper Klamath Lake and to compare the ecological relationships before and after dam removal to understand response of UKL's ecosystem to the restoration effort. We expect to find decreases in water quality parameters such as temperature (Bednarek, 2001; Zaidel et al., 2021), pH (Nilsson & Renöfält, 2008), and nutrient content (Friedl G & Wuest A, 2002; Nilsson & Renöfält, 2008) but increases in dissolved oxygen after dam removal (Abbott et al., 2022). We also expected to see an increase in mean secchi measures coinciding with diminished cyanobacteria bloom occurrences (Peretyatko et al., 2012). Additionally, we anticipated that zooplankton populations would show an overall increase post-dam removal (Bellmore et al., 2019; Tullos et al., 2010). Determining UKL's response to the Chiloquin Dam removal is particularly important given the planned deconstruction of four other dams in the Klamath Basin beginning in 2023 (Genzoli et al., 2021). Insights gained by researching UKL before and after dam removal can be used to make more informed decisions for the entire watershed as dam removal projects progress.

## MATERIALS & METHODS

**Data** - All data for this study was collected through the Klamath Basin Monitoring Program (KBMP). UKL water quality has been monitored since 1990 by the Klamath Tribes (Kann & Perkins, 2021). Thirty years

(1990-2020) of water quality data taken from UKL is stored on the Klamath Basin Monitoring Program website (Klamath Basin Monitoring Program, 2023). Zooplankton and phytoplankton data is stored on the federal Water Quality Portal (National Water Quality Monitoring Council, n.d.). According to annual reports, water quality and plankton samples were collected bi-weekly each year from late April to October (Jassby & Kann, 2010; Kann, 2011, 2012, 2013, 2014). To investigate the impact of dam removal on water quality parameters, zooplankton communities, and the occurrence of cyanobacteria blooms in UKL, we selected seven water quality variables: temperature (Temp), pH, dissolved oxygen (DO), total phosphorus (TP), total nitrogen (TN), chlorophyll-a (Chl-a), and secchi depth and three zooplankton groups, daphnia (*Daphnia* spp.), chydorids (*Chydorus sphaericus*), and copepod nauplii (*Copepoda* spp.). We used *Aphanizomenon flos-aquae* presence/absence as a binary response variable. An outcome of absent was defined as a cell count of 0ug/L, and present was defined as a cell count  $\geq 1$ ug/L. These variables were selected from the literature based on observed relationships to cyanobacteria bloom formation, zooplankton populations, and water quality.

Samples were collected and analyzed according to Klamath Basin Monitoring Program standard operating procedures. Temperature, pH, and dissolved oxygen were recorded as the average of measures taken at multiple depths in the water column. Total phosphorus and zooplankton samples were taken as an integrated water column sample. Total phosphorus measures came from water samples collected with a “tube sampler”, and zooplankton samples were collected with a Schindler-Patalis trap (Jassby & Kann, 2010; Kann, 2011, 2012, 2013, 2014).

We used a ten-year dataset, five years prior to the dam removal in August 2008, and five after the dam removal. The entire thirty years of observations could not be used due to large periods of missing data. *A. flos-aquae* cell counts were missing for the year 2003, and zooplankton data was not available after January 2014. We used August 31, 2008 as the delineation point to create separate datasets – pre-dam removal and post-dam removal. One sample collected in August during the dam

deconstruction (taken Aug. 25, 2008) was included in the pre-dam removal dataset since natural hydrology had not been fully restored at that point. Variables were tested for normality with the Shapiro-Wilks tests from base R and skewness and kurtosis were assessed with the moments package (Komsta & Novometsky, 2022). Variables were transformed where necessary. We ran Pearson's correlation tests and multicollinearity tests on both the pre- and post- dam removal datasets with the stats and MASS packages (Becker et al., 1988; Venables & Ripley, 2002). TN and Chl-a were determined to be highly correlated with multiple independent variables in both datasets and had elevated VIF values. These two variables were removed. The variables contained in our final dataset are as seen in Table 1. *A. flos-aquae* cell counts were converted to a binary variable for both datasets. The final pre-dam removal dataset contained 592 observations with a prevalence rate of 83.78%, and the post-dam removal dataset contained 706 observations with a prevalence rate of 80.68%.

**Modeling approach and analysis** - Paired t-tests were performed to compare pre-dam removal levels to post-dam removal levels for each variable (independent and dependent) to determine if the individual variables showed significant changes after the dam removal. Cyanobacteria cell counts were used in place of the binary variable. Prior to running paired t-tests we subsampled our pre- and post- datasets in triplicate to create six subsets (three pre-dam removal and three post-dam removal) containing 500 observations each so that t-tests for each variable were repeated three times. We could not use the entire pre- and post- datasets due to the imbalance number of observations (pre-dam removal: 592 observations, post-dam removal: 706 observations).

Three approaches were used to investigate the relationships between our predictors and response variable (cyanos) before and after dam removal: logistic regression (LR), classification tree (CT), and random forest (RF). Each has its own set of strengths and weaknesses (Table 2). To assess model performance, we used six performance metrics including sensitivity, specificity, true skills statistic, accuracy, Cohen's kappa, and AUC. All modeling analyses were performed in R. All predictive metrics



were retrieved with the caret package using predicted binary outcomes (0/1) except for TSS and AUC (Kuhn, 2023). TSS was calculated manually using the formula  $SE + SP - 1$ , and AUC was retrieved with the pROC package using predicted outcome probabilities (0.0-1.0) (Robin, 2023) For all models and predictive metrics, we applied the default probability threshold of 0.5 (present  $\geq 0.5$ , absent  $< 0.5$ ).

Model training was carried out on 75% of the data for both the pre- and post-dam removal and was performed on 3 subsets. The result was six unique test/train subsets (3 for pre- dam removal dataset and 3 for post- dam removal dataset). We used the caret package in R to carry out all model training and testing (Kuhn, 2023). The RF and CT models were trained on each data subset using 10 cross-validations as our training control parameter. Prediction metrics were recorded for each model. We calculated the average and confidence interval ( $n=3$ ;  $\alpha=0.01$ ) for each metric. CT models overfit the training sets and were not as effective predictors so we produced untrained CT models with the rpart package (Therneau & Atkinson, 2022). Our CT and RF models were not improved by pruning or control metrics, so they were not applied to our final models. Though these two techniques are based on similar mechanisms, CT models provide detailed information about the relationships amongst the variables as well as the thresholds used to derive the final predictive model. RF models do not provide these insights into a dataset, but they use a powerful predictive algorithm that is more robust to overfitting and less influenced by individual datapoints than CT models (Cutler et al., 2007; Fox et al., 2017; Peretyatko et al., 2012).

LR Models were built with the MASS package by backward selection based on Akaike Information Criterion (AIC) to find the most parsimonious models (Venables & Ripley, 2002). We considered interaction terms by investigating the collinearity plots of all variables in each dataset. Single linear regressions were run for pairs of independent variables that appeared to have a relationship based on collinearity assessments. Statistical significance and adjusted  $R^2$  values were compared to determine which interaction terms may benefit our LR models. Three LR models were produced from

each dataset for further analysis. Models containing the same interaction terms were trained on both pre- and post-dam removal datasets - base model (no interaction), TP\*pH\*Temp, and TP\*DO\*Temp.

## RESULTS

**Pre- and post-dam removal comparative results** - T-tests showed significant ( $p < 0.05$ ) changes in all water quality parameters (Fig. 1). There were significant ( $p < 0.05$ ) decreases in cyanobacteria cell count (mean change:  $-9.4 \times 10^7$  cells/L), temperature (mean change:  $-0.65^\circ\text{C}$ ), total phosphorus (mean change:  $-26.1 \mu\text{g/L}$ ), pH (mean change:  $-0.16$ ), and secchi depth (mean change:  $-0.14\text{m}$ ). Cyanobacteria cell counts showed a significant ( $p < 0.05$ ) decrease, and dissolved oxygen increased significantly ( $p < 0.05$ ) (mean change:  $0.32\text{mg/L}$ ). Zooplankton groups had variable responses – chydorids decreased significantly ( $p < 0.05$ ) (mean change:  $-26.37 \mu\text{g/L}$ ) while copepods increased significantly ( $p < 0.05$ ) (mean change:  $1.44 \mu\text{g/L}$ ). Daphnia showed no significant ( $p > 0.050$ ) differences between pre- to post-dam removal datasets (mean change:  $-103.6 \mu\text{g/L}$ ).

**Pre-dam removal comparative model results** - The predictive power of the models for the pre-dam removal set were comparable (Table 3). The RF model outperformed the LR model and the CT in all metrics except in specificity for which the LR model had the best predictive performance ( $\text{CT} < \text{RF} < \text{LR} = 0.65 < 0.70 < 0.71$ ) and sensitivity for which the CT model performed best ( $\text{LR} < \text{RF} < \text{CT} = 0.94 < 0.95 < 0.96$ ). The RF model was clearly superior to the base/non-interaction LR models which indicates the presence of underlying interactions that should be incorporated into our LR model for more accurate predictions. For the pre-dam removal dataset, adding terms to account for the interactions between total phosphorus, dissolved oxygen, and temperature improved the predictive performance and the overall fit to the data when compared to the base LR model (Table 3). Adding interactions between pH and total phosphorus and pH and temperature ( $\text{pH} * \text{TP}$ ,  $\text{pH} * \text{Temp}$ ) improved the predictive abilities of the LR model beyond that of the previously mentioned interactions ( $\text{TP} * \text{DO} * \text{Temp}$ ). Although, based on this model's decreased fit ( $\text{TP} * \text{DO} * \text{Temp}$  pseudo- $R^2 > \text{pH} * \text{TP}$ ,  $\text{pH} * \text{Temp}$  pseudo- $R^2 = 0.573 > 0.563$ ) it's

increased predictive power may be a symptom of overfitting to the datapoints rather than providing the best description of the actual ecosystem through LR modeling. The lack of fit indicates the model is likely not reliable and may not consistently provide the most accurate predictions. For this reason, we used the TP\*DO\*Temp model for comparisons with the RF and CT algorithms.

Variable importance rankings for RF and CT models were similar in all three pre-dam removal subsets (Table 4). pH was ranked first for each model in each subset and daphnia was ranked last for both machine learning models. Chydorids were ranked second in all RF models and were in the top three for all CT models. Rankings for the other five variables did not have the same level of alignment across the two model types. The variable importance lists also support the variable selections for the LR model. Daphnia, which was ranked last for all variable importance lists was removed from the LR model through backward selection. Chydorids and pH were ranked at the top of the variable importance lists and played an important role in the predictive power and explained variance of the LR models. Even though pH was not significant in the LR model for the first train/test subset, removing it did not improve the model. This may indicate that this variable is not particularly instrumental in fitting the data to the LR line but is an important factor in determining when conditions are right for bloom formation.

The CT model placed chydorids at the top of the tree with a threshold of 1.1ug/L (Fig. 2). In 59% of observations chydorids > 1.1ug/L resulting in bloom presence probability of 0.99. In the case that the chydorids < 1.1ug/L then pH, temperature, total phosphorus, dissolved oxygen, secchi, and copepods played a role in predicting bloom presence/absence. Measurements of pH > 7.8, total phosphorus > 99ug/L, and temperature > 13°C were the thresholds strongly associated with bloom presence. A pH >= 7.8 was the most important factor in dictating bloom presence when chydorid < 1.1ug/L. Chydorids > 1.1ug/L and pH >= 7.8 together explained 95.45% of all positive outcomes (probability > 0.50) for the pre-dam removal dataset.

**Post-dam removal comparative model results** – The RF model for the post-dam removal dataset was superior to the other two models in all predictive performance metrics (Table 3). For the post-dam removal dataset, the RF model was much superior to the base LR model indicating that interaction terms would benefit the LR algorithm’s predictive performance. Adding an interaction between temperature and dissolved oxygen (Temp\*DO) improved the LR model’s AUC, but all other predictive metrics remained the same. Including the Temp\*DO interaction also improved the fit of the model compared to the base model which was illustrated with a decreased mean AIC ( $255.96 < 256.59$ , respectively) and increased mean pseudo- $R^2$  ( $0.542 > 0.537$ , respectively). However, the best LR model for the post-dam removal dataset included interactions among pH, total phosphorus, and temperature (pH\*TP\*Temp). This model was superior across all predictive metrics as well as fit to the data (Table 3), and was used to compare to models from the RF and CT algorithms.

Variable importance rankings from CT and RF models had strong alignment across all three subsets – temperature and total phosphorus were ranked first and second, respectively, and chydorids were ranked last (Table 5). Daphnia was consistently seventh (above chydorids) in all three RF post-dam models and the first CT model but was sixth, above secchi, in the second and third CT models. For all post-dam RF models and the second and third CT model pH was third, but the first CT model ranked pH as fourth, below copepoda in the first CT model. Dissolved oxygen, copepoda, secchi were less consistent in the variable importance rankings for both models across all three subsets.

The post-dam CT model placed Temp at the top of the tree with the threshold set at  $15^{\circ}\text{C}$  (Fig. 3). 56% of all observations in the post-dam removal dataset exhibited temperature  $> 15^{\circ}\text{C}$  and pH  $> 7.9$  resulting in a bloom presence probability of 1.0. When temperature  $< 15^{\circ}\text{C}$  the Total phosphorus threshold,  $>85\mu\text{g/L}$  was the most important predictor of bloom presence. Temperature  $> 15^{\circ}\text{C}$ , pH  $> 7.9$ , and Total phosphorus  $> 85\mu\text{g/L}$  were the thresholds most strongly associated with bloom presence for

the post-dam removal dataset. Together Temperature > 15°C, pH > 7.9 and Total phosphorus > 85ug/L accounted for 87.95% of all positive outcomes ( $P > 0.50$ ).

## DISCUSSION

In the years since the dam removal there has been little visible recovery in UKL (Burdick, Hereford, et al., 2020; Burdick, Hewitt, et al., 2020; Burdick & Martin, 2017). However, it may take years or decades for large-scale ecological reversals to develop. Our study was conducted to examine changes in water quality parameters and zooplankton in UKL after the Chiloquin Dam removal and determine if the observed changes led to a decrease in cyanobacteria bloom occurrence. Our results showed a 3.1% decrease in bloom occurrence related to changes in multiple physico-chemical parameters post-dam removal.

Secchi depths showed an average decrease from 0.9935m to 0.8503m (14.41% change). Secchi depth values can serve as a strong predictor of algal abundance (Peretyatko et al., 2012). However, secchi depth measures are not specific to algal abundance, but are general measure of turbidity, or water clarity, which may be diminished by other particulate in the water such as sediment or organic detritus. The Chiloquin Dam reservoir was estimated to contain 49,000 - 61,000 tons of sediment prior to the dam removal (Bauer, 2009). The year after the Chiloquin Dam was removed the Sprague River experienced extremely low flows which limited sediment transport. However, there was evidence of fine sediment leaving the reservoir and moving swiftly downstream (Tullos et al., 2010). Studies have found that the increased turbidity in post-dam removal conditions may reduce the aquatic invertebrate populations downstream of the dam site until water clarity returns. When the populations rebuild the community may shift in response to the new flow regime and other related conditions (Bellmore et al., 2019).

The post-dam removal zooplankton community differed from the pre-dam removal community in UKL. Copepod nauplii biomass experienced an average increase of 20.8% and there was a 62.9% average decrease in the chydorid population. This may be why chydorids were no longer a useful predictor of bloom presence for the post-dam removal dataset. The change in flow rates and accompanying environmental shifts that take place post-dam removal can control the zooplankton community composition based on taxa-specific characteristics and thresholds (Bellmore et al., 2019; Czerniawski & Domagała, 2014). For instance, the species of chydorid found in UKL, *Chydorus sphaericus*, is often associated with eutrophic lakes. It can be found perching on cyanobacteria colonies. Additionally, their thoracic limbs are adapted to scrape off pieces of filamentous and colonial cyanobacteria small enough for consumption (de Eyto & Irvine, 2001; Tönno et al., 2016). Eyto & Irvine (2001) reported that *Chydorus sphaericus* egg development times are inversely related to both water temperature and pH, maturing faster as temperatures increased from 12°C – 20°C and in pH > 6.6. The observed decline in chydorids may be in response to the lowered water temperatures in UKL or the increased water velocity may interfere with their ability to remain perched on the cyanobacteria colonies thereby preventing feeding and possibly hindering the mating process (Czerniawski & Domagała, 2014). Copepod abundance can also be impacted by pH, but the thresholds vary based on specific taxa – calanoids thrive in pH < 6.0 but have more limited growth in pH > 6.0 when the average lake depth = < 2.5m (Min et al., 2021). Multiple studies have shown that various copepod species demonstrate an inverse relationship between water temperatures and various reproductive success metrics such as clutch size, individual nauplii size, and final adult size, but a direct positive relationship with egg development times, so copepod populations tend to thrive in cooler waters (Herzig, 1983; Lee et al., 2003). Copepods tend to be selective feeders that use chemosensory mechanisms to avoid cyanobacteria (Ger et al., 2014). Previous studies showed that *Daphnia* have an affinity for low flow systems (Czerniawski & Domagała 2014) and warmer waters (Stitch & Lampert, 1984) indicating they may be negatively impacted by dam removals.

Additionally, *Daphnia* can adapt to a diet composed mainly of colonial and filamentous cyanobacteria and may even graze down blooms if populations are large enough. However, *Daphnia* showed no significant change in biomass after dam removal, ranked low in variable importance in both datasets, and were not incorporated into pre- or post- CT models. Their relationship to the blooms may have been minimized by a couple of different factors. First, *Daphnia*'s large size relative to other zooplankton make them subject to higher rates of fish predation in eutrophic waters, thus driving the population down and limiting their impact on blooms (Ekvall et al., 2014; Ger et al., 2014; Tönno et al., 2016). Additionally, cyanotoxin analyses indicate that the strain of *A. flos-aquae* in UKL is non-toxic, which diminishes the stress placed on zooplankton by the bloom (Carmichael et al., 2000). The changes observed in chydorids and copepod nauplii are likely best explained by the taxa-specific limitations imposed by the new flow regime, the resulting physico-chemical changes, and reduced bloom presence in UKL post-dam removal (Bellmore et al., 2019; Czerniawski & Domagała, 2014). Whereas *Daphnia* biomass was less influenced by the changes in post-dam removal than other environmental factors.

Dam removals often lead to the release of organic matter from the prior reservoir site. Aerobic decomposition of the imported organic matter releases CO<sub>2</sub> which acidifies the water . (Nilsson & Renöfält, 2008). As previously discussed, pH can be limiting to *A. flos-aquae* bloom development as it cannot bloom if pH < 7.1 (Yamamoto & Nakahara, 2005). The lowest pH recorded during our sample months was 7.147, so pH was never low enough to prevent blooms. However, *A. flos-aquae* is limited to a minimal growth rate when pH is between 7.1 and 7.4 (Yamamoto & Nakahara, 2005; 2006). The mean pH decreased from 8.854 to 8.698 post-dam removal. Though this is not a large change it may have still been impactful. As previously mentioned, studies have shown that limited total phosphorus availability elevates *A. flos-aquae*'s temperature threshold (Yamamoto & Nakahara, 2006). However, they did not examine how diminished total phosphorus levels may impact the pH thresholds. In our CT models the pH threshold increased slightly from 7.8 to 7.9 post-dam removal. Additionally, pH was incorporated in the

interaction term in place of dissolved oxygen for the post-dam removal LR model along with temperature and total phosphorus. Our results indicate that pH thresholds may increase in response to low phosphorus concentrations much like the temperature thresholds.

Prior to dam removal the reservoir impounded by the Chiloquin Dam was approximately 1.8 times the width of the Sprague River. Zaidel et al (2021) found that the magnitude of warming in an impoundment and downstream is positively predicted by the width of an impoundment relative to the river width. The increased surface area makes the water subject to excessive warming by solar radiation. The temperature increase was also directly related to water residence time. Restoring flow mitigated these two factors thereby reducing water temperatures in UKL by 3.8%.

Increased connectivity also benefitted the eutrophic state of a waterbody (Friedl G & Wuest A, 2002; Nilsson & Renöfält, 2008). Total phosphorus levels decreased by 15.6% which has been shown to exhibit high levels of control over blooms (Yamamoto & Nakahara, 2006). In their review, Nilsson & Renöfält (2008) discuss how water volume controls nutrient concentrations. Additionally, elevated flow facilitates interactions between water and riparian plants. Through these interactions the river can offload excess nutrients into streamside vegetation thereby diminishing nutrient levels that continue downstream (Nilsson & Renöfält 2008). In the early 21st century thousands of acres of wetlands were restored on the north side of UKL so that once the dam was removed and downstream water volume increased the nutrient burden on the lake would be diminished (Burdick & Martin, 2017). Additionally, the Link River Dam is used to regulate outflow and keep lake levels between 4,137ft and 4,143ft (Snyder D.T. & Morace JL 1997). Increased inflows after the Chiloquin Dam deconstruction would require increased outflows through the Link River Dam to maintain constant lake elevation levels. As water leaves UKL it would carry nutrients with it, decreasing the effects of nutrient recycling common to reservoirs (Bushaw-Newton et al 2002; Friedl G & Wuest A 2002; Stanley Emily H & Doyle Martin W 2003).



UKL still experiences large diel fluctuations in dissolved oxygen when a bloom is present (Burdick, Hereford et al 2020; Burdick, Hewitt, et al 2020) indicating that *A. flos-aquae* blooms have a large amount of influence over dissolved oxygen levels in the lake (Abbott et al 2022). However, mean post-dam removal dissolved oxygen levels increased from 8.141mg/L to 8.464mg/L, despite the decrease in bloom occurrence. This implies an external source of O<sub>2</sub> has increased influence and blooms had less control over dissolved oxygen levels in the lake post-dam removal. Studies have shown that as dams decrease flow rates, they encourage stratification. This causes surface water temperatures to rise which decreases O<sub>2</sub> solubility leaving photosynthetic processes as the main source of dissolved oxygen (Abbott et al 2022; Bednarek 2001). Conversely, when flow is returned dissolved oxygen increases as surface temperatures decrease and the water is aerated through increased velocity and wave action (Abbott et al 2022; Friedl G & Wuest A 2002; Zappa et al 2007). This is likely one reason why the LR interaction term changed from TP\*DO\*Temp to TP\*pH\*Temp – dissolved oxygen levels were not as closely related to photosynthesis rates in post-dam removal UKL. Also, changes in dissolved oxygen and temperature may have contributed to the reduction of total phosphorus by reducing stratification and increasing oxygen levels in the benthos. Hypoxia near the water-sediment interface causes the reduction of the iron hydroxide layer that otherwise builds up on top of the sediment. This diminishes the sediment's ability to retain phosphorus, thus allowing it to be released and contribute to the eutrophication of the waterbody (Friedl G & Wuest A 2002). The changes in the lake post-dam removal would have lessened the effects of this phenomenon which may serve as another explanation as to why the TP\*DO\*Temp interaction was not as beneficial to the post-dam removal LR model.

Our t-tests showed decreases in our response variable. Cyanobacteria average biomass decreased by 33.33%, and bloom prevalence decreased by 3.1%. Temperature and total phosphorus appear to have played the largest role in bloom reduction based on their increased predictive power in the post-dam removal models. Prior research indicates that *A. flos-aquae* is

highly sensitive to changes in water temperatures, pH, and phosphorus availability. Yamamoto & Nakahara reported in 2005 that *A. flos-aquae* should bloom at 14<sup>0</sup>C if pH is above 7.1. However, their study in 2006 showed that when phosphorus is not readily available, such as in the presence of competitors, *A. flos-aquae* requires higher water temperatures, at least 19<sup>0</sup>C, before it can bloom. This synergistic control over the cyanobacteria's capacity to bloom was illustrated in our machine learning models. Temperature and total phosphorus became limiting factors as their observed levels decreased post-dam removal. As a result, they moved to the top of the variable importance rankings. Also, in our CT models total phosphorus thresholds decreased while temperature thresholds increased. In the pre-dam removal model there was a higher probability of bloom occurrence when total phosphorus was > 99ug/L. This threshold decreased to > 85ug/L post-dam removal. This would seem to be in response to the reduction in total phosphorus concentrations in the lake. However, the temperature threshold most associated with bloom presence increased from > 13<sup>0</sup>C pre-dam removal to > 15<sup>0</sup>C post-dam removal. This upward shift in the threshold contrasts with the changes observed in UKL - mean water temperatures decreased from 17.25<sup>0</sup>C to 16.6<sup>0</sup>C. Based on Yamamoto & Nakahara's (2006) findings the co-occurring reductions in temperature and total phosphorus explain the reduction in bloom occurrence.

## CONCLUSIONS

Prior studies have stated that an impact control element is crucial for ensuring that the changes observed in a waterway were caused by the dam removal, and not by random chance (Bellmore et al 2017). We understand that the lack of an impact control element in our study limits what conclusions we may draw regarding whether any changes observed in UKL's ecosystem are in direct response to the Chiloquin Dam removal. However, this investigation was conducted many years after the dam removal

took place, so setting up control impact sites for comparison was not an option. Additionally, hydrological and geomorphic investigations of the Chiloquin Dam removal confirmed the flow regime was altered downstream of the dam removal site (Tullos et al 2010). We have based our conclusions about changes in UKL on the known relationship between the hydrology of a waterbody and its physico-chemical properties (Bednarek 2001; Freidl & Wüest 2002; Nilsson & Renöfält 2008; Kim et al 2021).

Dam removals present unique opportunities to study how changes in flow regime influence riverine ecosystems and human impacts to those systems. Water quality parameters in UKL changed after the Chiloquin Dam was removed which reduced both cyanobacteria bloom prevalence and *Chydorus sphaericus* biomass, a species often associated with eutrophic systems. However, additional studies incorporating multiple dam removal sites with associated cyanobacterial blooms are needed to better understand how dams and dam removals impact cyanobacteria development.

Although cyanobacteria blooms are still a yearly occurrence and the endangered fish species in UKL have not recovered, our results indicate that the ecosystem is on a positive trajectory towards recovery. It is important to remember that reversing 100 years of accumulated environmental damage may take decades. Additionally, UKL is still under a restricted flow regime with low outflow. Based on our research removing the Link River Dam may be the next step to fully restore UKL to a healthy ecosystem.

## REFERENCES

- Abbott KM, Zaidel PA, Roy AH, Houle KM & Nislow KH. (2022). Investigating impacts of small dams and dam removal on dissolved oxygen in streams. *PLOS ONE*, 17(11).  
<https://doi.org/10.1371/journal.pone.0277647>
- Baldwin DS, Wilson J, Gigney H & Boulding A. (2009). Influence of extreme drawdown on water quality downstream of a large water storage reservoir. *River Research and Applications*, n/a-n/a.  
<https://doi.org/10.1002/rra.1255>
- Bauer T. (2009). Sediment considerations for potential dam removal projects Appendix E: Chiloquin Dam.
- Becker RA, Chambers JM, & Wilks AR (1988). *The New S Language*. Wadsworth & Brooks/Cole.
- Bednarek AT. (2001). Undamming rivers: A review of the ecological impacts of dam removal. *Environmental Management*, 27(6), 803–814. <https://doi.org/10.1007/s002670010189>
- Bellmore JR, Pess GR, Duda JJ, O'Connor JE, East A E, Foley MM, Wilcox AC, Major JJ, Shafroth PB, Morley SA, Magirl CS, Anderson CW, Evans JE, Torgersen C E, & Craig Laura S. (2019). Conceptualizing ecological responses to dam removal: if you remove it, what's to come? *BioScience*, 69(1), 26–39.  
<https://doi.org/10.1093/biosci/biy152>
- Berens McCabe EJ, Wells RS, Toms CN, Barleycorn AA, Wilkinson, KA, & Palubok, VI. (2021). Effects of multiple *Karenia brevis* red tide blooms on a common bottlenose dolphin (*Tursiops truncatus*) prey fish assemblage: Patterns of resistance and resilience in Sarasota Bay, Florida. *Frontiers in Marine Science*, 8.  
<https://doi.org/10.3389/fmars.2021.711114>
- Bortleson GC, & Fretwell MO. (1993). A review of possible causes of nutrient enrichment and decline of endangered sucker populations in Upper Klamath Lake, Oregon.
- Bradbury JP, Colman SM, & Reynolds RL. (2004). The history of recent limnological changes and human impact on Upper Klamath Lake, Oregon. *Journal of Paleolimnology*, 31, 151–165.
- Burdick SM., Hereford DM, Conway CM, Banet NV, Powers R, Martin BA., Elliott DG. (2020). Mortality of endangered juvenile Lost River Suckers associated with cyanobacteria blooms in mesocosms in Upper Klamath Lake, Oregon. *Transactions of the American Fisheries Society*, 149, 245–265.  
<https://doi.org/10.1002/tafs.10227>
- Burdick SM, Hewitt DA, Martin BA, Schenk L., Rounds SA. (2020). Effects of harmful algal blooms and associated water-quality on endangered Lost River and shortnose suckers. *Harmful Algae*, 97, 101847.  
<https://doi.org/10.1016/j.hal.2020.101847>
- Burdick SM, & Martin BA. (2017). Inter-annual variability in apparent relative production, survival, and growth of juvenile Lost River and Shortnose Suckers in Upper Klamath Lake, Oregon, 2001–15.
- Bushaw-Newton KL, Hart DD, Pizzuto JE, Thomson JR, Egan J, Ashley JT, Johnson TE, Horwitz RJ, Keeley M, Lawrence J, Charles D, Gatenby C., Kreeger DA, Nightengale T, Thomas RL, & Velinsky DJ. (2002). An integrative approach towards understanding ecological responses to dam removal: The Manatawny Creek study. *Journal of the American Water Resources Association*, 38(6), 1581–1599.
- Caldwell Eldridge SL, Wood TM, Echols KR, & Topping BR. (2013). Microcystins, nutrient dynamics, and other environmental factors during blooms of non-microcystin-producing *Aphanizomenon flos-aquae* in

Upper Klamath Lake, Oregon, 2009. *Lake and Reservoir Management*, 29, 68–81.  
<https://doi.org/10.1080/10402381.2013.775199>

Carmichael WW, Drapeau C, & Anderson DM. (2000). Harvesting of *Aphanizomenon flos-aquae* Ralfs ex Born. & Flah. var. *flos-aquae* (Cyanobacteria) from Klamath Lake for human dietary use. In *Journal of Applied Phycology* (Vol. 12).

Choi J, Min JO, Choi B, Kim D, Kang JJ, Lee SH, Choi K, Lee H, Jung J, & Shin KH. (2020). Key factors controlling primary production and cyanobacterial harmful algal blooms (cHABs) in a continuous weir system in the Nakdong River, Korea. *Sustainability*, 12(15). <https://doi.org/10.3390/su12156224>

Cutler DR, Edwards TC, Beard KH, Cutler A, Hess KT, Gibson J, & Lawler JJ. (2007). RANDOM FORESTS FOR CLASSIFICATION IN ECOLOGY. *Ecology*, 88(11), 2783–2792. <https://doi.org/10.1890/07-0539.1>

Czerniawski R, & Domagała J. (2014). Small dams profoundly alter the spatial and temporal composition of zooplankton communities in running waters. *International Review of Hydrobiology*, 99(4), 300–311. <https://doi.org/10.1002/iroh.201301674>

de Eyto E, & Irvine K. (2001). The response of three chydorid species to temperature, pH, and food. *Hydrobiologia*, 459(1/3), 165–172. <https://doi.org/10.1023/A:1012585217667>

Degerholm J, Gundersen K, Bergman B, & Söderbäck E. (2006). Phosphorus-limited growth dynamics in two Baltic Sea cyanobacteria, *Nodularia* sp. and *Aphanizomenon* sp. *FEMS Microbiology Ecology*, 58(3), 323–332. <https://doi.org/10.1111/j.1574-6941.2006.00180.x>

Ekvall MK., Urrutia-Cordero P, & Hansson LA. (2014). Linking Cascading Effects of Fish Predation and Zooplankton Grazing to Reduced Cyanobacterial Biomass and Toxin Levels Following Biomanipulation. *PLoS ONE*, 9(11). <https://doi.org/10.1371/journal.pone.0112956>

Ellsworth CM, Tyler TJ, VanderKooi SP, & Markle DF. (2009). Patterns of larval sucker emigration from the Sprague and lower Williamson Rivers of the Upper Klamath Basin, Oregon, prior to the removal of Chiloquin Dam— 2006 annual report.

Ellsworth CM, & VanderKooi SP. (2011). Spawning migration movements of Lost River and shortnose suckers in the Williamson and Sprague Rivers, Oregon, following the removal of Chiloquin Dam—2009 Annual Report.

Foley MM, Warrick JA, Ritchie A, Stevens AW, Shafroth PB, Duda JJ, Beirne MM, Paradis R, Gelfenbaum G, McCoy R. & Cubley ES. (2017). Coastal habitat and biological community response to dam removal on the Elwha River. *Ecological Monographs*, 87(4), 552–577. <https://doi.org/10.1002/ecm.1268>

Fox EW, Hill RA, Leibowitz SG, Olsen AR, Thornbrugh DJ, & Weber MH. (2017). Assessing the accuracy and stability of variable selection methods for random forest modeling in ecology. *Environmental Monitoring and Assessment*, 189(7), 316. <https://doi.org/10.1007/s10661-017-6025-0>

Friedl G & Wuest A. (2002). Disrupting biogeochemical cycles – Consequences of damming. *Aquatic Sciences*, 64, 55–65.

Genzoli L., Bandrowski DJ, Fricke S, McCovey B, Hillemeier D, Belchik M, Soto T, & Eds. (2021). Klamath Dam Removal Science Coordination Workshop Summary Report.

Ger KA, Hansson LA, & Lüring M. (2014). Understanding cyanobacteria-zooplankton interactions in a more eutrophic world. *Freshwater Biology*, 59, 1783–1798. <https://doi.org/10.1111/fwb.12393>

Helper TE, P. E. (n.d.). A CHILOQUIN ROMANCE - RESTORING THE SPRAGUE RIVER.

- Herzig A. (1983). The ecological significance of the relationship between temperature and duration of embryonic development in planktonic freshwater copepods. *Hydrobiologia*, 100, 65–91.
- Ho JC, Michalak AM, & Pahlevan N. (2019). Widespread global increase in intense lake phytoplankton blooms since the 1980s. *Nature*, 574, 667–670. <https://doi.org/10.1038/s41586-019-1648-7>
- Huisman J, Codd GA, Paerl HW, Ibelings BW, Verspagen JMH, & Visser PM. (2018). Cyanobacterial blooms. *Nature Reviews Microbiology*, 16, 471–483. <https://doi.org/10.1038/s41579-018-0040-1>
- Jassby A, & Kann J. (2010). Upper Klamath Lake monitoring program: preliminary analysis of status and trends for 1990-2009.
- Jeppesen E, Nöges P, Davidson TA, Haberman J, Nöges T, Blank K, Lauridsen TL, Søndergaard M, Sayer C, Laugaste R, Johansson LS, Bjerring R, & Amsinck SL. (2011). Zooplankton as indicators in lakes: a scientific-based plea for including zooplankton in the ecological quality assessment of lakes according to the European Water Framework Directive (WFD). *Hydrobiologia*, 676, 279–297. <https://doi.org/10.1007/s10750-011-0831-0>
- Kann J. (2011). Upper Klamath Lake 2010 Data Summary Report.
- Kann J. (2012). Upper Klamath Lake 2011 Data Summary Report.
- Kann J. (2013). Upper Klamath Lake 2012 Data Summary Report.
- Kann J. (2014). Upper Klamath Lake 2013 Data Summary Report.
- Kann J & Perkins K. (2021). Upper Klamath Lake 2020 Data Summary Report.
- Kim S, Mehrotra R, Kim S, & Sharma A. (2021). Assessing Countermeasure Effectiveness in Controlling Cyanobacterial Exceedance in Riverine Systems Using Probabilistic Forecasting Alternatives. *Journal of Water Resources Planning and Management*, 147, 040210621–040210629. [https://doi.org/10.1061/\(ASCE\)WR.1943-5452.0001449](https://doi.org/10.1061/(ASCE)WR.1943-5452.0001449)
- Klamath Basin Monitoring Program. (2023). Compilation of Klamath Tribes Upper Klamath Lake water quality data, 1990-2018 and 2020. Klamath Basin Monitoring Program: Maps and Monitoring Data. <https://kbmp.net/maps-and-data>
- Komsta L. & Novometsky F. (2022). moments: Moments, cumulants, skewness, kurtosis and related tests. R Package Version 0.14.1.
- Kuhn M. (2023). Package “caret”: classification and regression training. In CRAN Repository (pp. 1–224).
- Lee HW, Ban S, Ikeda T, & Matsuishi T. (2003). Effect of temperature on development, growth and reproduction in the marine copepod *Pseudocalanus newmani* at satiating food condition. *Journal of Plankton Research*, 25(3), 261–271. <https://doi.org/10.1093/plankt/25.3.261>
- Maavara T, Chen Q, Van Meter K, Brown LE, Zhang J, Ni J, & Zarfl C. (2020). River dam impacts on biogeochemical cycling. *Nature Reviews Earth & Environment*, 1, 103–116. <https://doi.org/10.1038/s43017-019-0019-0>
- Markle DF, & Clauson K. (2006). Ontogenetic and habitat-related changes in diet of late larval and juvenile suckers (Catastomidae) in Upper Klamath Lake, Oregon. *Western North American Naturalist*, 66(4), 492–501. [https://doi.org/10.3398/1527-0904\(2006\)66\[492: OAHCID\]2.0.CO;2](https://doi.org/10.3398/1527-0904(2006)66[492: OAHCID]2.0.CO;2)

- Martin BA, Echols Kathy R, Elliot DG, Feltz K, Conway CM, & Burdick SM. (2019). Effects of Microcystin-LR on Juvenile Lost River Suckers (*Deltistes luxatus*) during Feeding Trials, Upper Klamath Lake, Oregon, 2014–16. <https://doi.org/10.3133/ofr20191079>
- Min C, Johansson LS, Søndergaard M, Lauridsen TL, Chen F, Sh T, & Jeppesen E. (2021). Copepods as environmental indicator in lakes: special focus on changes in the proportion of calanoids along nutrient and pH gradients. *Aquatic Ecology*, 55, 1241–1252. <https://doi.org/10.1007/s10452-021-09877-y>
- National Water Quality Monitoring Council. (n.d.). Water Quality Portal (WQX). Retrieved August 11, 2021, from <https://www.waterqualitydata.us/#huc=18010203&sampleMedia=Biological&sampleMedia=Water&asssemblage=Phytoplankton%2FZooplankton&startDateLo=01-01-2003&startDateHi=12-31-2014&mimeType=csv&dataProfile=narrowResult&providers=NWIS&providers=STEWARDS&providers=STORET>.
- Nilsson C & Renöfält BM. (2008). Linking flow regime and water quality in rivers: a challenge to adaptive catchment management. *Ecology and Society*, 13(2). <https://www.jstor.org/stable/26268001>
- Osami K, Eisaku Y, Shinobu F, & Toyohisa M. (1998). A Study on the role of hydraulic retention time in eutrophication of the asahi river dam reservoir. *Water Science and Technology*, 37(2), 245–252. [https://doi.org/10.1016/S0273-1223\(98\)00030-4](https://doi.org/10.1016/S0273-1223(98)00030-4)
- Peretyatko A, Teissier S, De Backer S, & Triest L. (2012). Classification trees as a tool for predicting cyanobacterial blooms. *Hydrobiologia*, 689, 131–146. <https://doi.org/10.1007/s10750-011-0803-4>
- Robin X. (2023). Package pROC: display and analyze ROC curves. In CRAN Repository.
- Rouso BZ, Bertone E, Stewart R, & Hamilton DP. (2020). A systematic literature review of forecasting and predictive models for cyanobacteria blooms in freshwater lakes. *Water Research*, 182, 1–26. <https://doi.org/10.1016/j.watres.2020.115959>
- Ryan Bellmore J, Duda JJ, Craig LS, Greene SL, Torgersen CE, Collins MJ, & Vittum K. (2017). Status and trends of dam removal research in the United States. *Wiley Interdisciplinary Reviews: Water*, 4. <https://doi.org/10.1002/wat2.1164>
- Sevrin-Reyssac J, & Pletikosic M. (1990). Cyanobacteria in fish ponds. *Aquaculture*, 88(1), 1–20. [https://doi.org/10.1016/0044-8486\(90\)90315-E](https://doi.org/10.1016/0044-8486(90)90315-E)
- Smucker NJ, Beaulieu JJ, Nietch CT, & Young JL. (2021). Increasingly severe cyanobacterial blooms and deep water hypoxia coincide with warming water temperatures in reservoirs. *Global Change Biology*, 27(11), 2507–2519. <https://doi.org/10.1111/gcb.15618>
- Snyder D.T. & Morace JL. (1997). Nitrogen and phosphorus loading from drained wetlands adjacent to Upper Klamath and Agency Lakes.
- Stanley Emily H & Doyle Martin W. (2003). Trading off: the ecological effects of dam removal. *Frontiers in Ecology and the Environment*, 1(1), 15–22.
- Stitch HB & Lampert W. (1984). Growth and reproduction of migrating and non-migrating *Daphnia* species under simulated food and temperature conditions of diurnal vertical migration. *Oecologia*, 61, 192–196.
- Therneau T & Atkinson B. (2022). rpart: Recursive partitioning and regression trees. R Package Version 4.1.19.

- Tõnno I, Agasild H, Kõiv T, Freiberg R, Nõges P, & Nõges T. (2016). Algal diet of small-bodied crustacean zooplankton in a cyanobacteria-dominated eutrophic lake. *PLOS ONE*, 11(4).  
<https://doi.org/10.1371/journal.pone.0154526>
- Tullos D, Cox M & Walter C. (2010). Simulating dam removal with a 1D hydraulic model: Accuracy and techniques for reservoir erosion and downstream deposition at the chiloquin dam removal. *World Environmental and Water Resources Congress 2010*, 1737–1749.  
[https://doi.org/10.1061/41114\(371\)183](https://doi.org/10.1061/41114(371)183)
- Venables WN & Ripley BD. (2002). Modern applied statistics with S. in modern applied statistics with S (Fourth Edition).
- Wurts W, & Durborow RM. (1992). Interactions of pH, carbon dioxide, alkalinity, and hardness in fish ponds.
- Yamamoto Y, & Nakahara H. (2005). The formation and degradation of cyanobacterium *Aphanizomenon flos-aquae* blooms: the importance of pH, water temperature, and day length. *Limnology*, 6, 1–6.  
<https://doi.org/10.1007/s10201-004-0138-1>
- Yamamoto Y, & Nakahara H. (2006). Importance of interspecific competition in the abundance of *Aphanizomenon flos-aquae* (Cyanophyceae). *Limnology*, 7, 163–170. <https://doi.org/10.1007/s10201-005-0189-y>
- Zaidel PA, Roy AH, Houle KM, Lambert B, Letcher BH, Nislow KH, & Smith C. (2021). Impacts of small dams on stream temperature. *Ecological Indicators*, 120. <https://doi.org/10.1016/j.ecolind.2020.106878>
- Zappa CJ, McGillis WR, Raymond PA, Edson JB, Hintsä EJ, Zemmelen HJ, Dacey JWH, & Ho DT. (2007). Environmental turbulent mixing controls on air-water gas exchange in marine and aquatic systems. *Geophysical Research Letters*, 34, L10601. <https://doi.org/10.1029/2006GL028790>



Table 1 Variable Descriptions

**Table 1.** VARIABLES USED FOR ANALYSIS TO BUILD PREDICTIVE MODELS AND ASSESS LAKE HEALTH. PARAMETERS WERE SELECTED BASED ON RELATIONSHIPS TO ECOSYSTEM HEALTH AND EUTROPHIC STATE.

<u>Parameter</u>	<u>Relevance</u>	<u>Reference</u>
Total Phosphorus	Limiting essential nutrient for cyanobacteria growth	Snyder & Morace 1997; Winton et al 2019; Bradbury et al 2004; Kann 2011
Secchi Depth	Measure of water clarity related to presence of algae or other particulate or water velocity	Nilsson & Renöfält 2008; Bellmore 2019; Kann 2011
Dissolved Oxygen	Important element for aquatic life; Large diurnal fluctuations; Hypoxia during senescence	Burdick et al 2020a; Burdick et al 2020b; Bellmore et al 2019; Kann 2011
pH	Extreme highs and lows may be lethal to biota; <i>A. flos-aquae</i> cannot grow if pH<7.1; impounded lakes	Yamamoto & Nakahara 2005; Burdick et al 2020a; Burdick et al 2020b; Wuts & Durborow 1992; Kann 2011
Temperature	Influences zooplankton health and reproduction rates, <i>A. flos-aquae</i> cannot grow in waters below 11°C	Yamamoto & Nakahara 2005; Eyto & Irvine 2001; Tonno et al 2016; Min et al 2021; Herzig 1983; Kann 2011
Chydorids ( <i>Chydorus sphaericus</i> )	Juvenile sucker food source, often found in eutrophic lakes, can consume filamentous cyanobacteria, impacted by water quality parameters	Markle & Clausen 2006; Tonno et al 2016; Eyto & Irvine 2001; Bellmore 2019; Kann 2011
Copepods (nauplii)	Juvenile sucker food source, population impacted by water quality parameters, grazing may control or encourage cyanobacteria growth	Markle & Clausen 2006; Ekvall et al 2014; Aguilera et al 2020; Lee et al 2003; Bellmore 2019; Kann 2011
Daphnia	Juvenile sucker food source, population impacted by various water quality parameters, grazing may control cyanobacteria growth	Markle & Clausen 2006; Urrutia-Corderro et al 2016; Ekvall et al 2014; Bellmore 2019; Kann 2011
<i>Aphanizomenon flos-aquae</i>	Response variable, indicates trophic state, sensitive to pH, temperature, and total phosphorus, related to secchi depth and dissolved oxygen, effects health of other biota	Yamamoto & Nakahara 2005; Burdick et al 2020a; Burdick et al 2020b; Bradbury 2004; Morace & Snyder 1997; Kann 2011

Table 2 Algorithm Strengths & Weaknesses

**TABLE. 2.** STRENGTHS AND WEAKNESSES OF THE THREE ALGORITHMS USED IN OUR ANALYSIS: LOGISTIC REGRESSION, CLASSIFICATION TREE, AND RANDOM FOREST.

MODEL ALGORITHM	Weaknesses	Strengths	Reference
LOGISTIC REGRESSION	<ul style="list-style-type: none"> <li>• Influenced by collinearity</li> <li>• Limited to defining the data and relationships based on fit to a line</li> </ul>	<ul style="list-style-type: none"> <li>• Shows relationships amongst the variables</li> <li>• Shows interactions amongst independent variables</li> <li>• Produces odds ratios that show strength and direction of influence of each independent term on the outcome variable.</li> </ul>	Cutler 2007; Ranganathan et al 2017; Liu et al 2013
CLASSIFICATION TREE	<ul style="list-style-type: none"> <li>• Easily influenced by individual datapoints</li> <li>• Prone to overfitting training dataset</li> </ul>	<ul style="list-style-type: none"> <li>• Show specific thresholds associated with presence/absence of response variable</li> <li>• Calculate probability of positive outcome for each combination of independent variables</li> <li>• Produces variable importance rankings</li> <li>• Can define non-linear relationships</li> </ul>	Fox et al 2017; Peretyatko et al 2012
RANDOM FOREST	<ul style="list-style-type: none"> <li>• Do not elaborate on relationships amongst variables</li> </ul>	<ul style="list-style-type: none"> <li>• Powerful predictive tool often superior to other algorithms</li> <li>• Can define non-linear relationships</li> <li>• Robust to collinearity</li> <li>• Robust to overfitting</li> </ul>	Fox et al 2017; Cutler et al 2007

## Variable Median Values Before and After Dam Removal

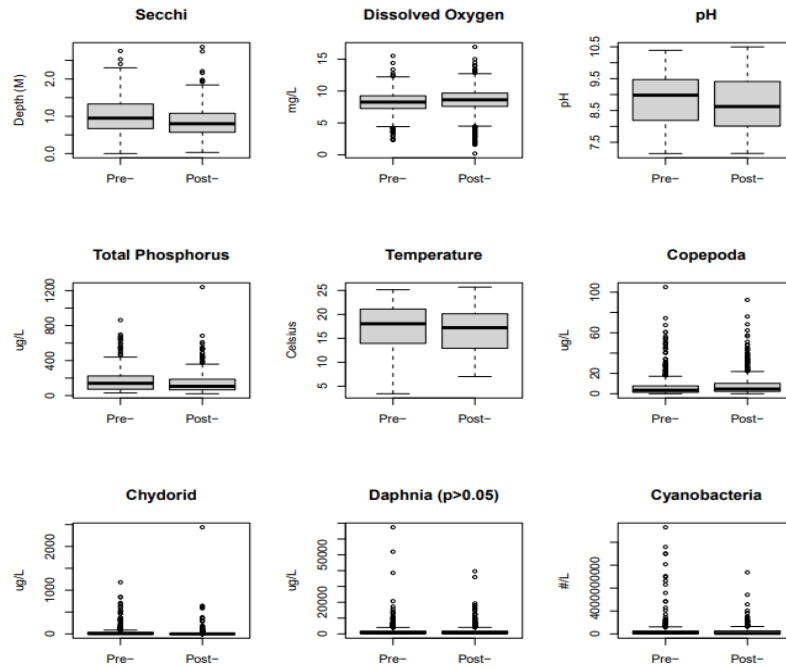

Figure 1 Pre-/Post- Boxplots

**Fig. 1.** BOXPLOTS SHOW VARIABLE CHANGES PRE-/POST- DAM REMOVAL. PAIRED T-TESTS SHOWED SIGNIFICANT DECREASE ( $p < 0.05$ ) IN CYANOBACTERIA, TOTAL PHOSPHORUS, TEMPERATURE, SECCHI DEPTH, AND CHYDORIDS, AND SIGNIFICANT INCREASE ( $p < 0.05$ ) IN DISSOLVED OXYGEN AND COPEPODS. DAPHNIA SHOWED NO SIGNIFICANT ( $p > 0.05$ ) CHANGE POST-DAM

Table 3 Model Prediction Results

**Table. 3.** MEAN OF PREDICTIVE METRICS FROM THE 3 TRAIN/TEST SUBSETS FOR EACH MODEL BEFORE AND AFTER DAM REMOVAL ± CONFIDENCE INTERVAL (alpha = 0.01; n=3). SEPARATED BY ALGORITHM AND DATASET. BLUE HI-LIGHT INDICATES BEST PERFORMING LR MODEL, AND YELLOW HI-LIGHT INDICATES BEST PERFORMING MODEL AMONGST ALGORITHMS.

Dataset	Model	Sensitivity	Specificity	True Skill Statistic	Accuracy	Kappa	AUC
Pre-Dam Removal	Logistic Regression (base)	0.93 ± 0.009	0.65 ± 0.158	0.59 ± 0.150	0.89 ± 0.015	0.58 ± 0.097	0.93 ± 0.039
	Logistic Regression (tp*do*temp)	0.94 ± 0.009	0.71 ± 0.166	0.64 ± 0.160	0.9 ± 0.026	0.62 ± 0.108	0.94 ± 0.023
	Random Forest	0.95 ± 0.017	0.7 ± 0.091	0.65 ± 0.107	0.91 ± 0.031	0.67 ± 0.101	0.96 ± 0.023
	Classification Tree	0.96 ± 0.030	0.65 ± 0.302	0.61 ± 0.327	0.91 ± 0.065	0.64 ± 0.292	0.9 ± 0.026
Post-Dam Removal	Logistic Regression (base)	0.91 ± 0.052	0.68 ± 0.045	0.59 ± 0.026	0.87 ± 0.031	0.58 ± 0.075	0.91 ± 0.037
	Logistic Regression (pH*tp, pH*temp)	0.92 ± 0.030	0.72 ± 0.026	0.64 ± 0.039	0.88 ± 0.030	0.62 ± 0.060	0.93 ± 0.023
	Random Forest	0.96 ± 0.037	0.76 ± 0.052	0.72 ± 0.031	0.92 ± 0.017	0.74 ± 0.043	0.94 ± 0.009
	Classification Tree	0.93 ± 0.030	0.66 ± 0.068	0.59 ± 0.054	0.88 ± 0.017	0.6 ± 0.045	0.87 ± 0.026

Table 4 Variable Importance Rankings

<b>Table 4.</b> PRE-DAM REMOVAL VARIABLE IMPORTANCE RANKINGS FROM MACHINE LEARNING MODELS; SEPARATED BY MODEL TYPE AND TRAIN/TEST SUBSETS.		
	<b>Random Forest (Pre-)</b>	<b>Classification Tree (Pre-)</b>
<b>Subset 1</b>	<ol style="list-style-type: none"> <li>1. PH</li> <li>2. Chydorid</li> <li>3. Secchi</li> <li>4. Temp</li> <li>5. TP</li> <li>6. Copepoda</li> <li>7. DO</li> <li>8. Daphnia</li> </ol>	<ol style="list-style-type: none"> <li>1. PH</li> <li>2. Chydorid</li> <li>3. Temp</li> <li>4. TP</li> <li>5. Secchi</li> <li>6. Copepoda</li> <li>7. DO</li> <li>8. Daphnia</li> </ol>
<b>Subset 2</b>	<ol style="list-style-type: none"> <li>1. PH</li> <li>2. Chydorid</li> <li>3. Temp</li> <li>4. Secchi</li> <li>5. TP</li> <li>6. DO</li> <li>7. Copepod</li> <li>8. Daphnia</li> </ol>	<ol style="list-style-type: none"> <li>1. PH</li> <li>2. Temp</li> <li>3. Chydorid</li> <li>4. TP</li> <li>5. Secchi</li> <li>6. Copepod</li> <li>7. DO</li> <li>8. Daphnia</li> </ol>
<b>Subset 3</b>	<ol style="list-style-type: none"> <li>1. PH</li> <li>2. Chydorid</li> <li>3. Temp</li> <li>4. Copepod</li> <li>5. TP</li> <li>6. Secchi</li> <li>7. DO</li> <li>8. Daphnia</li> </ol>	<ol style="list-style-type: none"> <li>1. PH</li> <li>2. Chydorid</li> <li>3. TP</li> <li>4. Temp</li> <li>5. Copepod</li> <li>6. Secchi</li> <li>7. DO</li> <li>8. Daphnia</li> </ol>

## Pre-Dam Removal Classification Tree

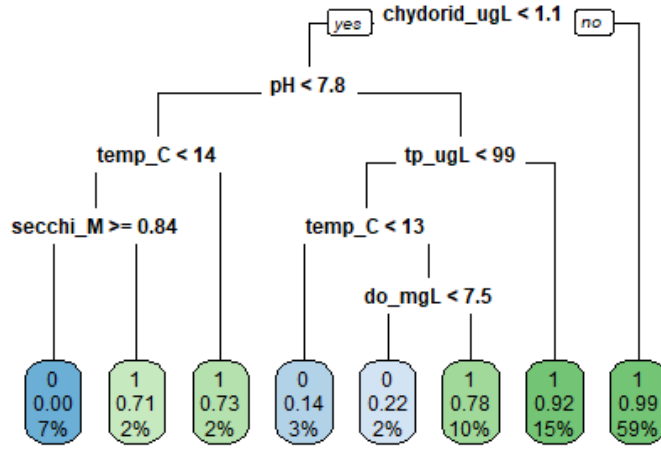

Figure 2 Pre-Removal Classification Tree

**Fig. 2.** CLASSIFICATION TREE FOR PRE-DAM REMOVAL DATASET. SHOWS RELATIONSHIPS AMONGST WATER QUALITY PARAMETERS AND ZOOPLANKTON, AND THEIR RELATIONSHIP TO *A. flos-aquae* BLOOM OCCURRENCE. GREEN FINAL NODES INDICATE AN OUTCOME OF “1” (PRESENT) AND BLUE NODES INDICATE AN OUTCOME OF “0” (ABSENT). PERCENTAGES SHOW THE RATION OF DATA REPRESENTED BY THE CONDITIONS LEADING TO THAT FINAL NODE, AND PROBABILITIES SHOW THE CHANCE OF BLOOM OCCURRENCE.

Table 5 Variable Importance Rankings

<b>Table 5.</b> POST-DAM REMOVAL VARIABLE IMPORTANCE RANKINGS FROM MACHINE LEARNING MODELS; SEPARATED BY MODEL TYPE AND TRAIN/TEST SUBSETS.		
	<b>Random Forest (Post-)</b>	<b>Classification Tree (Post-)</b>
<b>Subset 1</b>	<ol style="list-style-type: none"> <li>1. Temp</li> <li>2. TP</li> <li>3. PH</li> <li>4. Copepods</li> <li>5. DO</li> <li>6. Secchi</li> <li>7. Daphnia</li> <li>8. Chydorids</li> </ol>	<ol style="list-style-type: none"> <li>1. Temp</li> <li>2. TP</li> <li>3. Copepods</li> <li>4. pH</li> <li>5. DO</li> <li>6. Secchi</li> <li>7. Daphnia</li> <li>8. Chydorids</li> </ol>
<b>Subset 2</b>	<ol style="list-style-type: none"> <li>1. Temp</li> <li>2. TP</li> <li>3. PH</li> <li>4. Copepods</li> <li>5. DO</li> <li>6. Secchi</li> <li>7. Daphnia</li> <li>8. Chydorids</li> </ol>	<ol style="list-style-type: none"> <li>1. Temp</li> <li>2. TP</li> <li>3. PH</li> <li>4. Copepods</li> <li>5. DO</li> <li>6. Daphnia</li> <li>7. Secchi</li> <li>8. Chydorids</li> </ol>
<b>Subset 3</b>	<ol style="list-style-type: none"> <li>1. Temp</li> <li>2. TP</li> <li>3. PH</li> <li>4. DO</li> <li>5. Copepods</li> <li>6. Secchi</li> <li>7. Daphnia</li> <li>8. Chydorids</li> </ol>	<ol style="list-style-type: none"> <li>1. Temp</li> <li>2. TP</li> <li>3. PH</li> <li>4. DO</li> <li>5. Copepods</li> <li>6. Daphnia</li> <li>7. Secchi</li> <li>8. Chydorids</li> </ol>

### Post-Dam Removal Classification Tree

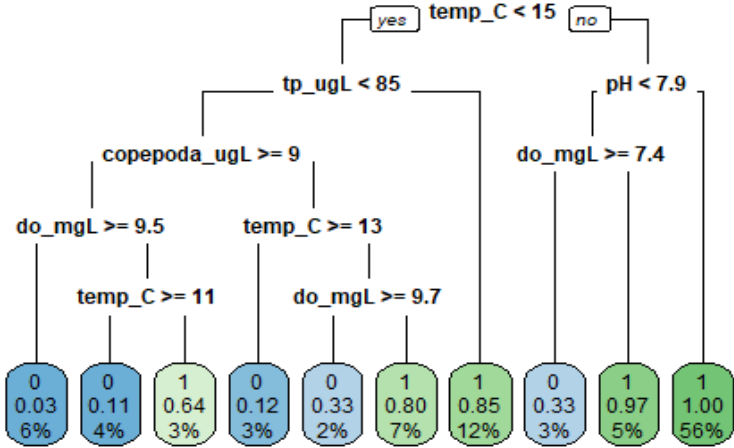

Figure 3 Post-Removal Classification Tree

**Fig. 3.** CLASSIFICATION TREE FOR POST-DAM REMOVAL DATASET. SHOWS RELATIONSHIPS AMONGST WATER QUALITY PARAMETERS AND ZOOPLANKTON, AND THEIR RELATIONSHIP TO *A. flos-aquae* BLOOM OCCURRENCE. GREEN FINAL NODES INDICATE AN OUTCOME OF “1” (PRESENT) AND BLUE NODES INDICATE AN OUTCOME OF “0” (ABSENT). PERCENTAGES SHOW THE RATION OF DATA REPRESENTED BY THE CONDITIONS LEADING TO THAT FINAL NODE, AND PROBABILITIES SHOW THE CHANCE OF BLOOM OCCURRENCE.